

ATRIUM MINI PLUS

VER. 2.0

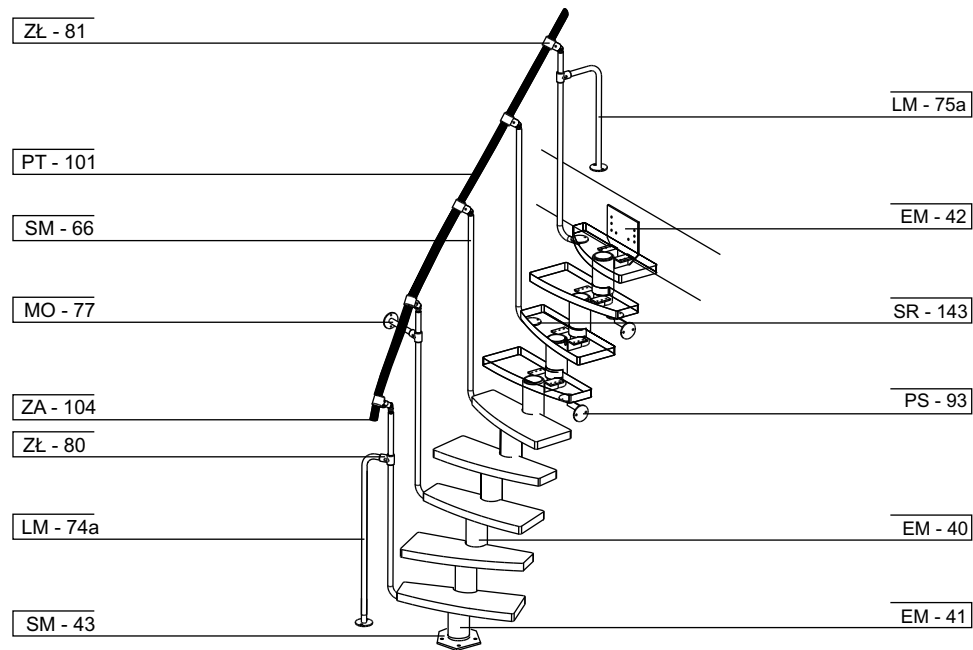

~ 130 kg

Atrium Sp.j., 41-100 Siemianowice Śląskie, ul. Konopnickiej 11, tel. (+48 32) 609 00 01, 609 00 05, fax. (+48 32) 609 19 00, www.atriumsystem.com.pl

ATRIUM MINI PLUS

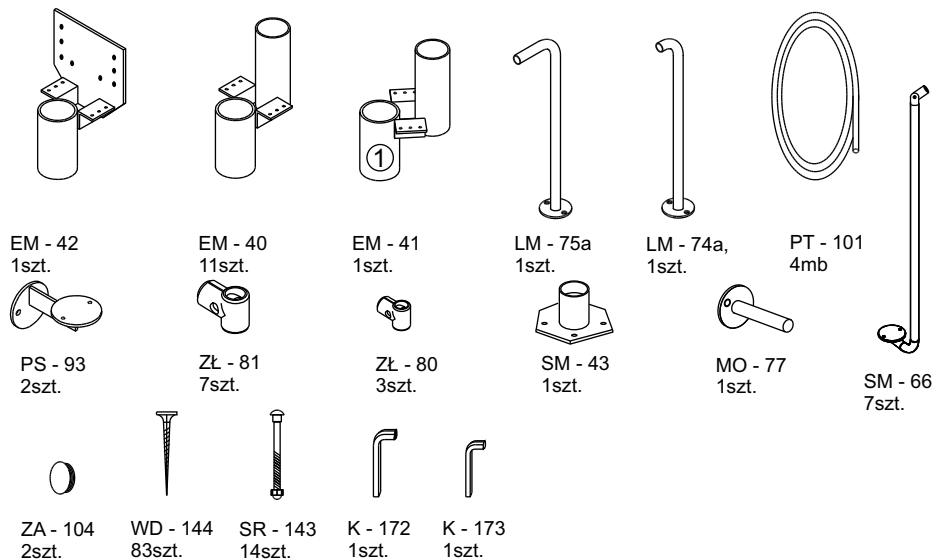
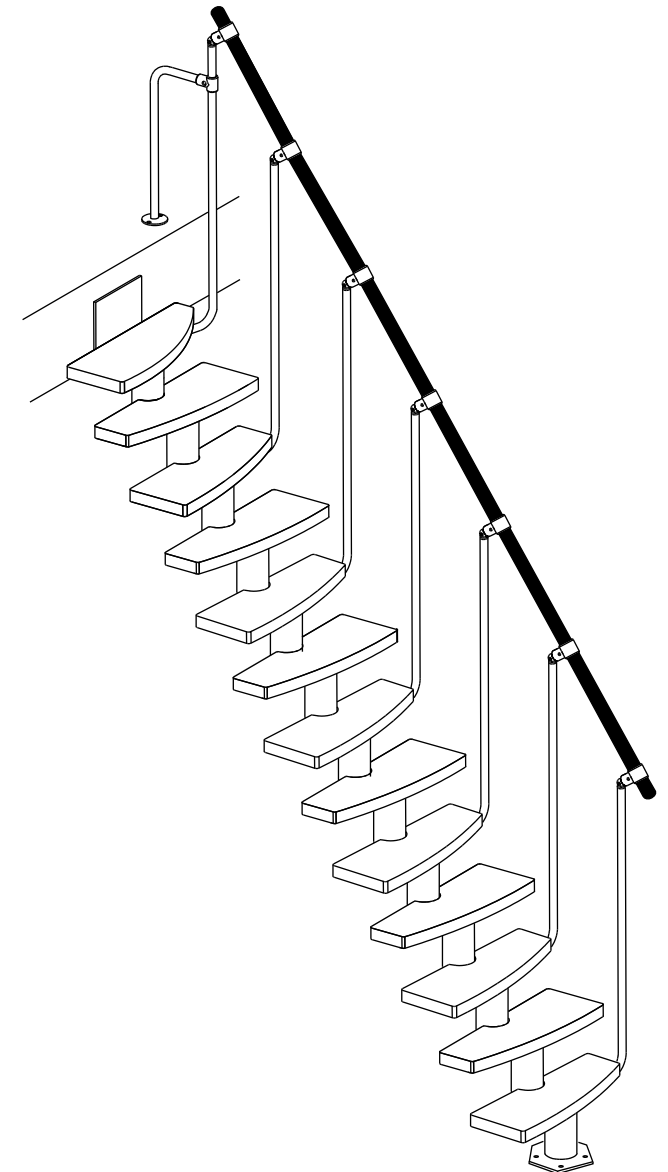

ATRIUM MINI PLUS

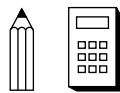

VER. 2.0

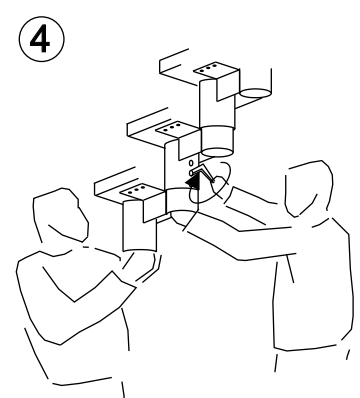
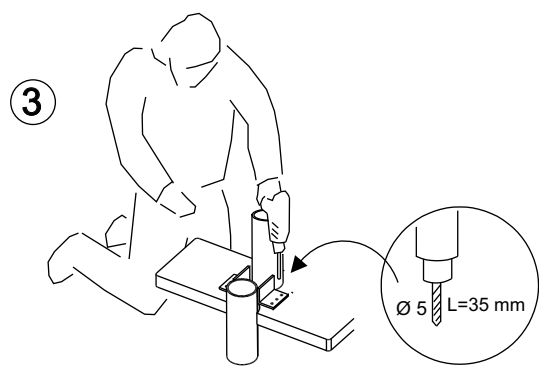
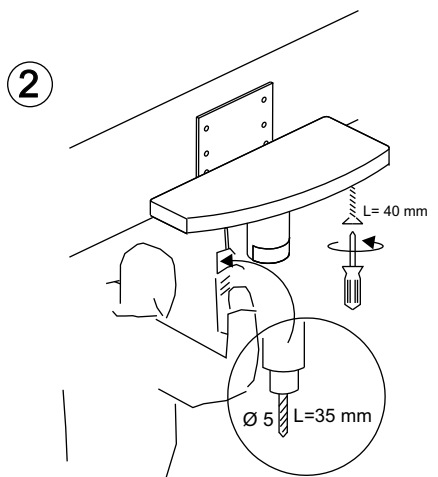
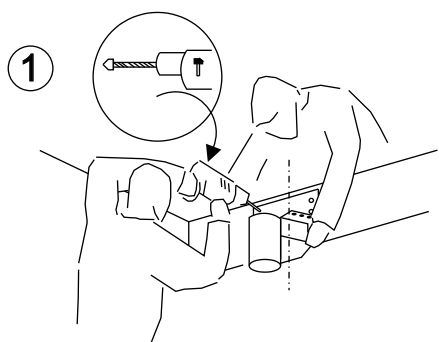
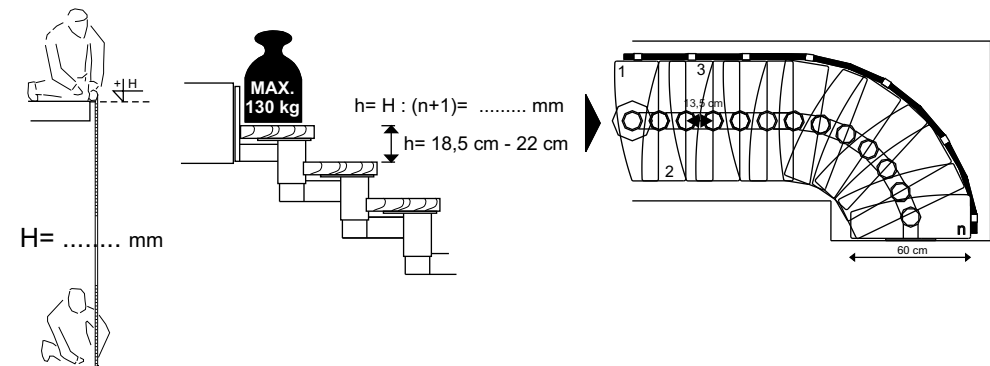

ATRIUM MINI PLUS

VER. 2.0

